

**VALVE OPERATING NUT EXTENSION**

EXTENSIONS ARE REQUIRED WHEN THE VALVE NUT IS MORE THAN THREE (3) FEET BELOW FINISHED GRADE. EXTENSIONS ARE TO BE A MINIMUM OF ONE (1) FOOT LONG, ONLY ONE EXTENSION PER VALVE. ALL EXTENSIONS ARE TO MADE OF STEEL SIZED AS NOTED, AND PAINTED WITH TWO COATS OF CARBON ELASTIC (ATCO NO. 2221) AS SPECIFIED BY PRESERVATIVE PAINT CO. OR APPROVED EQUAL.

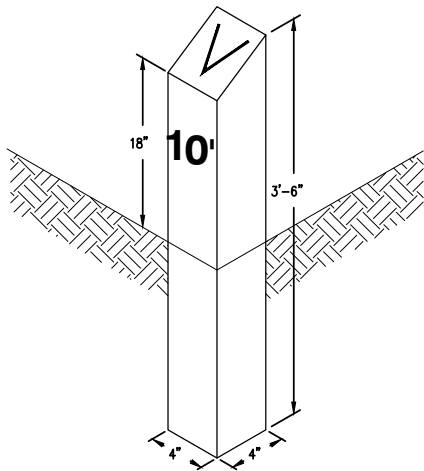

**VALVE MARKER POST**

VALVE MARKER POST SHALL BE A RENTON CONCRETE PRODUCTS NO. VM-1 OR APPROVED EQUAL. VALVE MARKER SHALL BE PAINTED WITH TWO COATS OF SHERWIN WILLIAMS INDUSTRIAL ENAMEL B66 ACRYLIC BLUE. THE POST SHALL BE SITUATED IN A SAFE AND REASONABLY CONSPICUOUS LOCATION AT A RIGHT ANGLE TO THE ROADWAY FROM THE VALVE. DISTANCE TO THE VALVE SHALL BE NEATLY STENCILED ON THE POST WITH TWO-INCH NUMBERS WITH BLACK PAINT.

VALVE MARKERS ARE NOT REQUIRED WHEN VALVES ARE LOCATED WITHIN PAVED SURFACES.

**GATE VALVE EXTENSION & MARKER**

WATER STANDARD DETAIL  
W-19

UNION HILL  
WATER ASSOCIATION

SCALE: NTS	DATE: JUNE 10, 2019
R:\CAD\DETAIL\AUTOCAD\UHWA\W-19 VLV EXT MK	